

CD74HCT4051-Q1
HIGH-SPEED CMOS LOGIC
ANALOG MULTIPLEXER/DEMULTIPLEXER

SCLS569B – JANUARY 2004 – REVISED APRIL 2008

- **Qualified for Automotive Applications**
- **Wide Analog Input Voltage Range:**
±5 V Max
- **Low ON Resistance**
 - 70 Ω Typical ($V_{CC} - V_{EE} = 4.5\text{ V}$)
 - 40 Ω Typical ($V_{CC} - V_{EE} = 9\text{ V}$)
- **Low Crosstalk Between Switches**
- **Fast Switching and Propagation Speeds**
- **Break-Before-Make Switching**
- **Wide Operating Temperature Range: –40°C to 125°C**
- **Operation Control Voltage: 4.5 V to 5.5 V**
- **Switch Voltage: 0 V to 10 V**
- **Direct LSTTL Input Logic Compatibility:**
 $V_{IL} = 0.8\text{ V Max}$, $V_{IH} = 2\text{ V Min}$
- **CMOS Input Compatibility: $I_I \leq 1\ \mu\text{A}$ at V_{OL} , V_{OH}**

description/ordering information

This device is a digitally controlled analog switch that utilizes silicon-gate CMOS technology to achieve operating speeds similar to LSTTL, with the low power consumption of standard CMOS integrated circuits.

This analog multiplexer/demultiplexer controls analog voltages that may vary across the voltage supply range (i.e., V_{CC} to V_{EE}). It is a bidirectional switch that allows any analog input to be used as an output and vice-versa. The switch has low ON resistance and low OFF leakages. In addition, this device has an enable control that, when high, disables all switches to their OFF state.

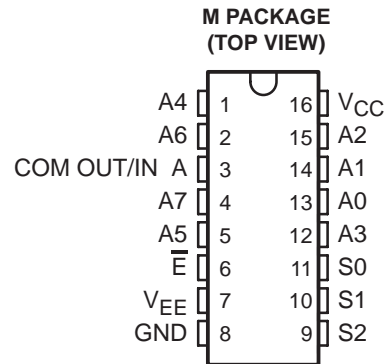

ORDERING INFORMATION†

T _A	PACKAGE‡		ORDERABLE PART NUMBERS§	TOP-SIDE MARKING
–40°C to 125°C	SOIC – M	Reel of 2500	CD74HCT4051QM96Q1	HCT4051Q

† For the most current package and ordering information, see the Package Option Addendum at the end of this document, or see the TI web site at <http://www.ti.com>.

‡ Package drawings, thermal data, and symbolization are available at <http://www.ti.com/packaging>.

§ The suffix 96 denotes tape and reel.



Please be aware that an important notice concerning availability, standard warranty, and use in critical applications of Texas Instruments semiconductor products and disclaimers thereto appears at the end of this data sheet.

PRODUCTION DATA information is current as of publication date. Products conform to specifications per the terms of Texas Instruments standard warranty. Production processing does not necessarily include testing of all parameters.



POST OFFICE BOX 655303 • DALLAS, TEXAS 75265

Copyright © 2008, Texas Instruments Incorporated

CD74HCT4051-Q1 HIGH-SPEED CMOS LOGIC ANALOG MULTIPLEXER/DEMULTIPLEXER

SCLS569B – JANUARY 2004 – REVISED APRIL 2008

FUNCTION TABLE

INPUTS				ON CHANNELS
ENABLE	S2	S1	S0	
L	L	L	L	A0
L	L	L	H	A1
L	L	H	L	A2
L	L	H	H	A3
L	H	L	L	A4
L	H	L	H	A5
L	H	H	L	A6
L	H	H	H	A7
H	X	X	X	None

X = Don't care

logic diagram (positive logic)

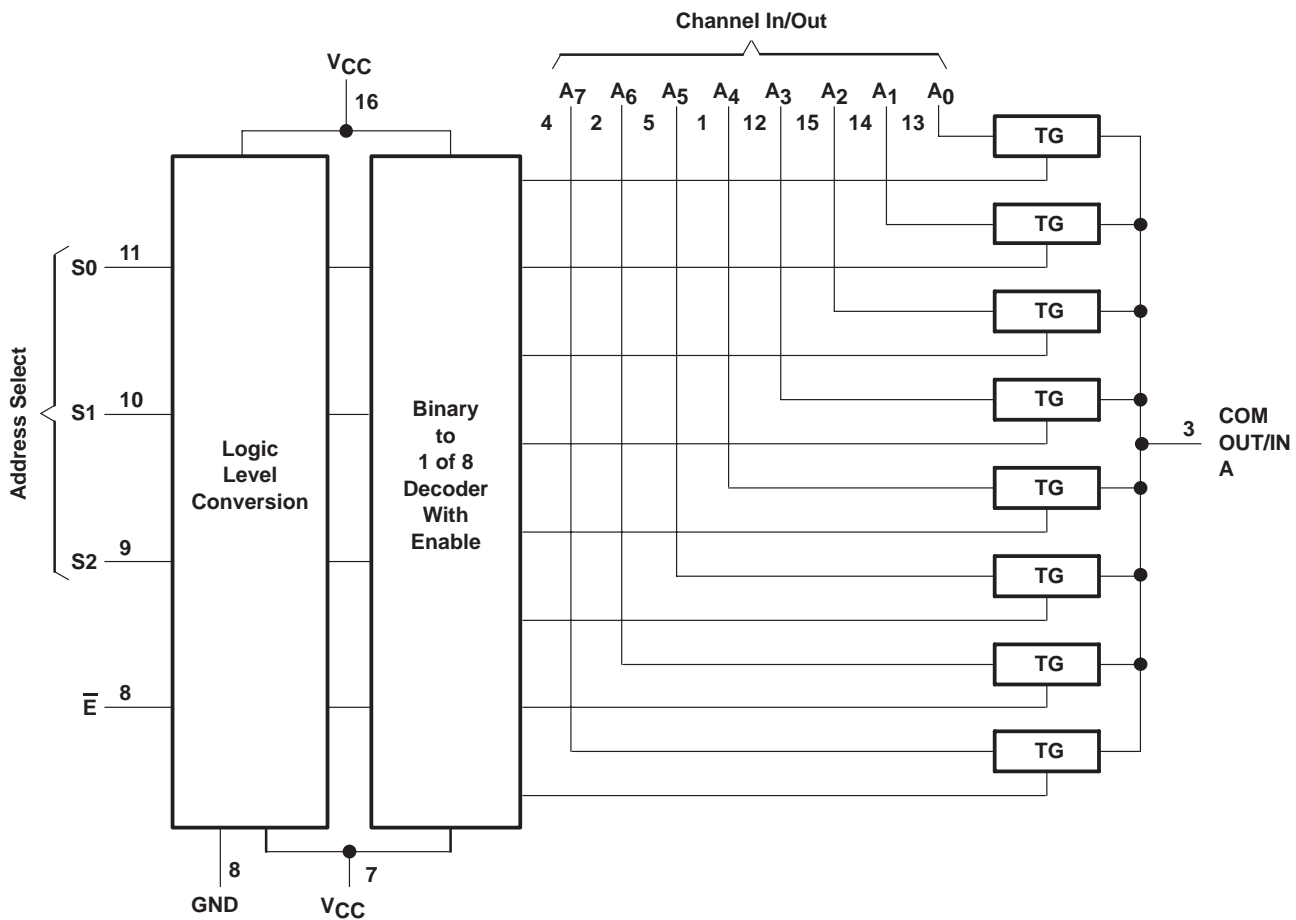

absolute maximum ratings over operating free-air temperature range (unless otherwise noted)†

Supply voltage range: $V_{CC} - V_{EE}$ (see Note 1)	-0.5 V to 10.5 V
V_{CC}	-0.5 V to +7 V
V_{EE}	0.5 V to -7 V
Input clamp current, I_{IK} ($V_I < -0.5$ V or $V_I > V_{CC} + 0.5$ V)	±20 mA
Output clamp current, I_{OK} ($V_O < V_{EE} - 0.5$ V or $V_O > V_{CC} + 0.5$ V)	±20 mA
Switch current ($V_I > V_{EE} - 0.5$ V or $V_I < V_{CC} + 0.5$ V)	±25 mA
Continuous current through V_{CC} or GND	±50 mA
V_{EE} current, I_{EE}	-20 mA
Package thermal impedance, θ_{JA} (see Note 2)	73°C/W
Maximum junction temperature, T_J	150°C
Lead temperature (during soldering):	
At distance 1/16 ± 1/32 inch (1,59 ± 0,79 mm) from case for 10 s max	300°C
Storage temperature range, T_{stg}	-65°C to 150°C

† Stresses beyond those listed under “absolute maximum ratings” may cause permanent damage to the device. These are stress ratings only, and functional operation of the device at these or any other conditions beyond those indicated under “recommended operating conditions” is not implied. Exposure to absolute-maximum-rated conditions for extended periods may affect device reliability.

- NOTES: 1. All voltages referenced to GND unless otherwise specified.
2. The package thermal impedance is calculated in accordance with JESD 51-7.

recommended operating conditions (see Note 3)

		MIN	MAX	UNIT
V_{CC}	Supply voltage	4.5	5.5	V
	Supply voltage, $V_{CC} - V_{EE}$ (see Figure 1)	2	10	V
V_{EE}	Supply voltage (see Note 4 and Figure 2)	0	-6	V
V_{IH}	High-level input voltage	2		V
V_{IL}	Low-level input voltage		0.8	V
V_I	Input control voltage	0	V_{CC}	V
V_{IS}	Analog switch I/O voltage	V_{EE}	V_{CC}	V
t_t	Input transition (rise and fall) time		$V_{CC} = 4.5$ V	ns
T_A	Operating free-air temperature	-40	125	°C

- NOTES: 3. All unused inputs of the device must be held at V_{CC} or GND to ensure proper device operation. Refer to the TI application report, *Implications of Slow or Floating CMOS Inputs*, literature number SCBA004.
4. In certain applications, the external load resistor current may include both V_{CC} and signal-line components. To avoid drawing V_{CC} current when switch current flows into the transmission gate inputs, the voltage drop across the bidirectional switch must not exceed 0.6 V (calculated from r_{ON} values shown in electrical characteristics table). No V_{CC} current flows through R_L if the switch current flows into the COM OUT/IN A terminal.

CD74HCT4051-Q1

HIGH-SPEED CMOS LOGIC

ANALOG MULTIPLEXER/DEMULTIPLEXER

SCLS569B – JANUARY 2004 – REVISED APRIL 2008

recommended operating area as a function of supply voltages

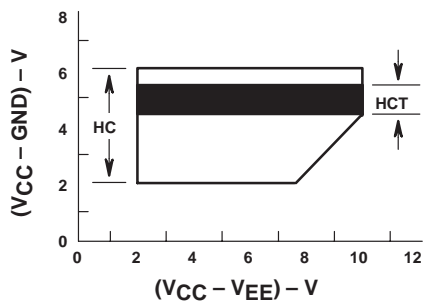

Figure 1

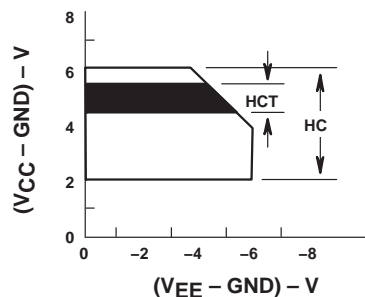

Figure 2

electrical characteristics over recommended operating free-air temperature range (unless otherwise noted)

PARAMETER	TEST CONDITIONS	V _{EE}	V _{CC}	T _A = 25°C			T _A = -40°C TO 125°C		UNIT	
				MIN	TYP	MAX	MIN	MAX		
r _{on}	I _O = 1 mA, V _I = V _{IH} or V _{IL} , See Figure 9	V _{IS} = V _{CC} or V _{EE}	0 V	4.5 V	70	160	240		Ω	
			-4.5 V	4.5 V	40	120	180			
		V _{IS} = V _{CC} to V _{EE}	0 V	4.5 V	90	180	270			
			-4.5 V	4.5 V	45	130	195			
Δr _{on}	Between any two channels	0 V	4.5 V	10					Ω	
		-4.5 V	4.5 V	5						
I _{IZ}	For switch OFF: When V _{IS} = V _{CC} , V _{OS} = V _{EE} ; When V _{IS} = V _{EE} , V _{OS} = V _{CC} For switch ON: All applicable combinations of V _{IS} and V _{OS} voltage levels, V _I = V _{IH} or V _{IL}	0 V	6 V	±0.2			±2		μA	
		-5 V	5 V	±0.4			±4			
I _{IL}	V _I = V _{CC} or GND	Control input		5.5 V	±0.1			±1		μA
I _{CC}	I _O = 0, V _I = V _{CC} or GND	When V _{IS} = V _{EE} , V _{OS} = V _{CC}	0 V	5.5 V	8			160		μA
		When V _{IS} = V _{CC} , V _{OS} = V _{EE}	-4.5 V	5.5 V	16			320		
ΔI _{CC}	Per input pin: 1 unit load, See Note 5, V _{IN} = V _{CC} - 2.1 V			4.5 V to 5.5 V	100	360	490		μA	

NOTE 5: For dual-supply systems, theoretical worst case (V_I = 2.4 V, V_{CC} = 5.5 V) specification is 1.8 mA.

HCT input loading

TYPE	INPUT	UNIT LOADS†
4051	All	0.5

† Unit load is ΔI_{CC} limit specified in the electrical characteristics table, e.g., 360 μA max at 25°C.

switching characteristics over recommended operating free-air temperature range (unless otherwise noted) (see Figure 8)

PARAMETER	FROM (INPUT)	TO (OUTPUT)	LOAD CAPACITANCE	V _{EE}	V _{CC}	T _A = 25°C			T _A = -40°C TO 125°C		UNIT
						MIN	TYP	MAX	MIN	MAX	
t _{pd}	IN	OUT	C _L = 15 pF		5 V	4					ns
			C _L = 50 pF	0 V	4.5 V	12			18		
			C _L = 50 pF	-4.5 V	4.5 V	8			12		
t _{en}	S or \bar{E}	OUT	C _L = 15 pF		5 V	23					ns
			C _L = 50 pF	0 V	4.5 V	55			83		
			C _L = 50 pF	-4.5 V	4.5 V	39			59		
t _{dis}	S or \bar{E}	OUT	C _L = 15 pF		5 V	19					ns
			C _L = 50 pF	0 V	4.5 V	45			68		
			C _L = 50 pF	-4.5 V	4.5 V	32			48		
C _I	Control					10			10	pF	

operating characteristics, V_{CC} = 5 V, T_A = 25°C, input t_r, t_f = 6 ns

PARAMETER		TYP	UNIT
C _{pd}	Power dissipation capacitance (see Note 6)	52	pF

NOTE 6: C_{pd} is used to determine the dynamic power consumption (P_D), per package.

$$P_D = (C_{pd} \times V_{CC}^2 \times f_i) + \sum (C_L + C_S) V_{CC}^2 \times f_O$$

f_O = output frequency

f_i = input frequency

C_L = output load capacitance

C_S = switch capacitance

V_{CC} = supply voltage

analog channel characteristics, T_A = 25°C

PARAMETER		TEST CONDITIONS	V _{EE}	V _{CC}	TYP	UNIT
C _I	Switch input capacitance				5	pF
C _{COM}	Common output capacitance				25	pF
f _{max}	Minimum switch frequency response at -3 dB	See Figure 3 and Figure 10 and Notes 7 and 8	-2.25 V	2.25 V	145	MHz
			-4.5 V	4.5 V	180	
	Sine-wave distortion	See Figure 5	-2.25 V	2.25 V	0.035	%
			-4.5 V	4.5 V	0.018	
	\bar{E} or address select (S0, S1, S2) to switch feedthrough noise	See Figure 6 and Notes 8 and 9	-2.25 V	2.25 V	TBE	mV
			-4.5 V	4.5 V	TBE	
	Switch OFF signal feedthrough	See Figure 7 and Figure 11 and Notes 8 and 9	-2.25 V	2.25 V	-73	dB
			-4.5 V	4.5 V	-75	

NOTES: 7. Adjust input voltage to obtain 0 dBm at V_{OS} for f_{IN} = 1 MHz.

8. V_{IS} is centered at (V_{CC} - V_{EE})/2.

9. Adjust input for 0 dBm.

PARAMETER MEASUREMENT INFORMATION

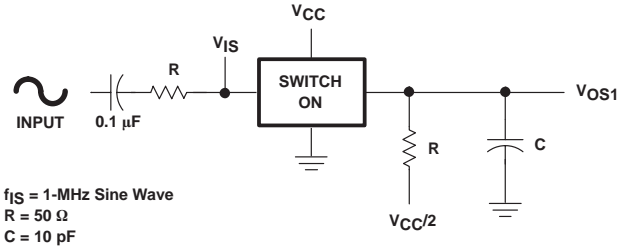

Figure 4. Crosstalk Between Two Switches Test Circuit

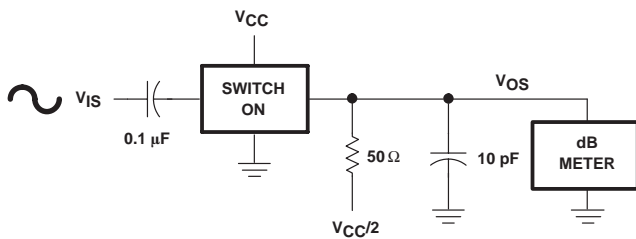

Figure 3. Frequency-Response Test Circuit

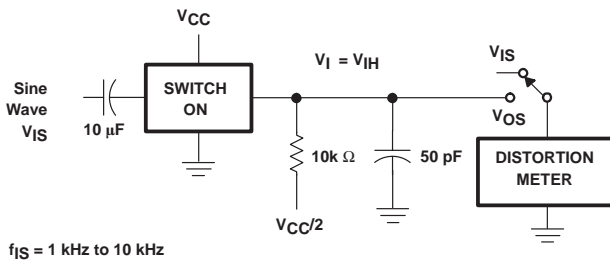
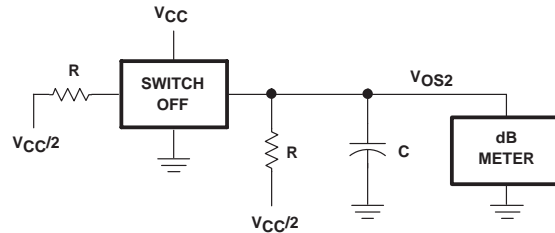

Figure 5. Sine-Wave Distortion Test Circuit

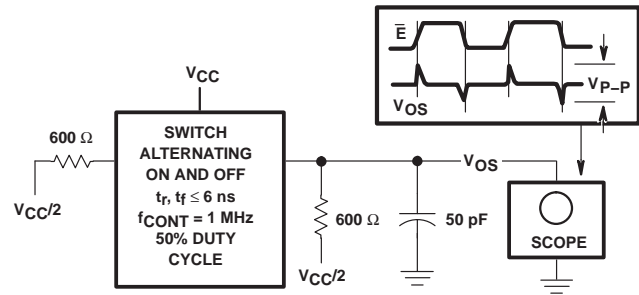

Figure 6. Control-to-Switch Feedthrough Noise Test Circuit

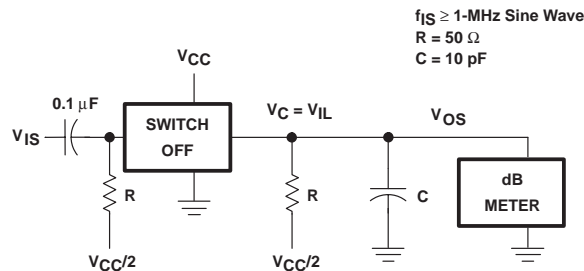
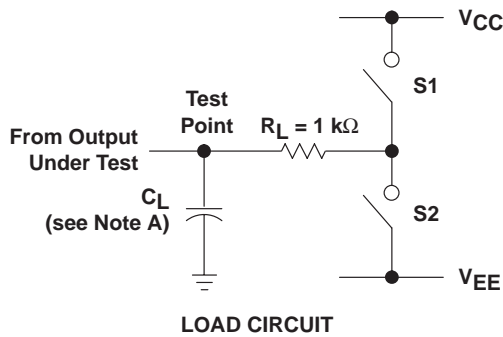
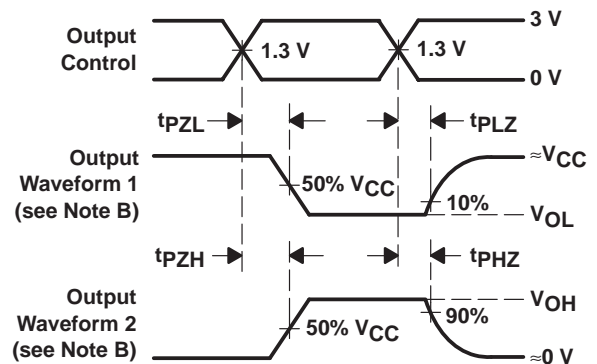
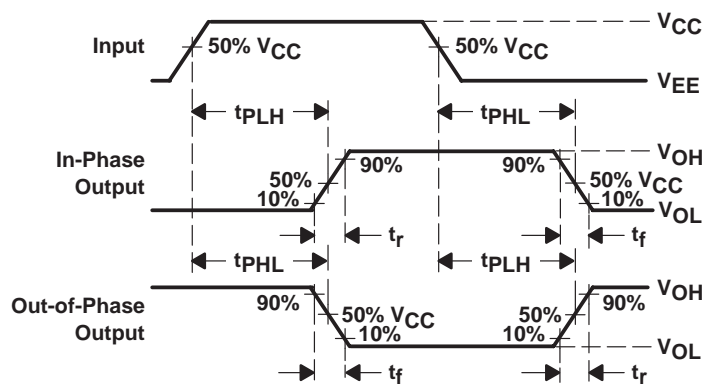

Figure 7. Switch OFF Signal Feedthrough Test Circuit

PARAMETER MEASUREMENT INFORMATION



PARAMETER		S1	S2
t_{en}	t_{PZH}	Open	Closed
	t_{PZL}	Closed	Open
t_{dis}	t_{PHZ}	Open	Closed
	t_{PLZ}	Closed	Open
t_{pd}		Open	Open



- NOTES:
- A. C_L includes probe and test-fixture capacitance.
 - B. Waveform 1 is for an output with internal conditions such that the output is low, except when disabled by the output control. Waveform 2 is for an output with internal conditions such that the output is high, except when disabled by the output control.
 - C. Phase relationships between waveforms were chosen arbitrarily. All input pulses are supplied by generators having the following characteristics: $PRR \leq 1$ MHz, $Z_O = 50 \Omega$, $t_r = 6$ ns, $t_f = 6$ ns.
 - D. For clock inputs, f_{max} is measured with the input duty cycle at 50%.
 - E. The outputs are measured one at a time, with one input transition per measurement.
 - F. t_{PLZ} and t_{PHZ} are the same as t_{dis} .
 - G. t_{PZL} and t_{PZH} are the same as t_{en} .
 - H. t_{PLH} and t_{PHL} are the same as t_{pd} .

Figure 8. Load Circuit and Voltage Waveforms

CD74HCT4051-Q1
HIGH-SPEED CMOS LOGIC
ANALOG MULTIPLEXER/DEMULTIPLEXER

SCLS569B – JANUARY 2004 – REVISED APRIL 2008

TYPICAL CHARACTERISTICS

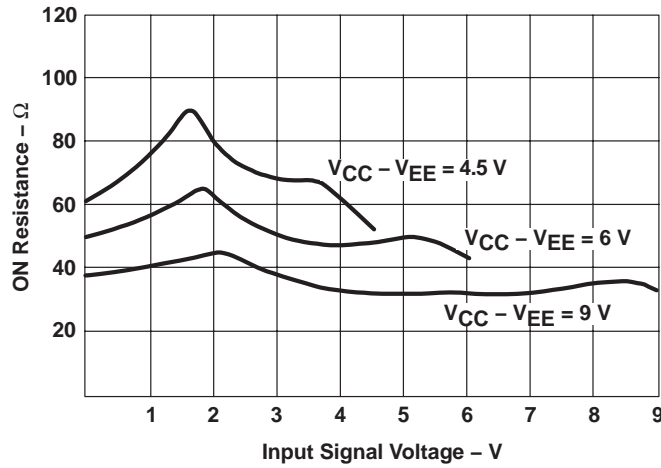

Figure 9. Typical ON Resistance vs Input Signal Voltage

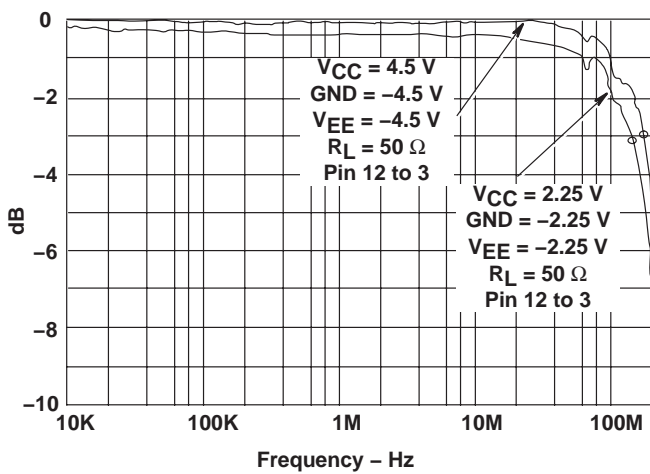

Figure 10. Channel ON Bandwidth

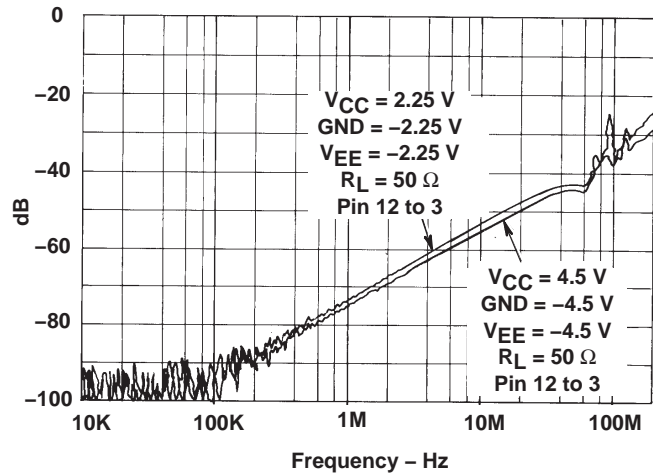

Figure 11. Channel OFF Feedthrough

PACKAGING INFORMATION

Orderable Device	Status ⁽¹⁾	Package Type	Package Drawing	Pins	Package Qty	Eco Plan ⁽²⁾	Lead/Ball Finish	MSL Peak Temp ⁽³⁾
CD74HCT4051QM96Q1	ACTIVE	SOIC	D	16	2500	Pb-Free (RoHS)	CU NIPDAU	Level-2-250C-1 YEAR/ Level-1-235C-UNLIM
D24051QM96G4Q1	ACTIVE	SOIC	D	16	2500	Green (RoHS & no Sb/Br)	CU NIPDAU	Level-1-260C-UNLIM

⁽¹⁾ The marketing status values are defined as follows:

ACTIVE: Product device recommended for new designs.

LIFEBUY: TI has announced that the device will be discontinued, and a lifetime-buy period is in effect.

NRND: Not recommended for new designs. Device is in production to support existing customers, but TI does not recommend using this part in a new design.

PREVIEW: Device has been announced but is not in production. Samples may or may not be available.

OBsolete: TI has discontinued the production of the device.

⁽²⁾ Eco Plan - The planned eco-friendly classification: Pb-Free (RoHS), Pb-Free (RoHS Exempt), or Green (RoHS & no Sb/Br) - please check <http://www.ti.com/productcontent> for the latest availability information and additional product content details.

TBD: The Pb-Free/Green conversion plan has not been defined.

Pb-Free (RoHS): TI's terms "Lead-Free" or "Pb-Free" mean semiconductor products that are compatible with the current RoHS requirements for all 6 substances, including the requirement that lead not exceed 0.1% by weight in homogeneous materials. Where designed to be soldered at high temperatures, TI Pb-Free products are suitable for use in specified lead-free processes.

Pb-Free (RoHS Exempt): This component has a RoHS exemption for either 1) lead-based flip-chip solder bumps used between the die and package, or 2) lead-based die adhesive used between the die and leadframe. The component is otherwise considered Pb-Free (RoHS compatible) as defined above.

Green (RoHS & no Sb/Br): TI defines "Green" to mean Pb-Free (RoHS compatible), and free of Bromine (Br) and Antimony (Sb) based flame retardants (Br or Sb do not exceed 0.1% by weight in homogeneous material)

⁽³⁾ MSL, Peak Temp. -- The Moisture Sensitivity Level rating according to the JEDEC industry standard classifications, and peak solder temperature.

Important Information and Disclaimer:The information provided on this page represents TI's knowledge and belief as of the date that it is provided. TI bases its knowledge and belief on information provided by third parties, and makes no representation or warranty as to the accuracy of such information. Efforts are underway to better integrate information from third parties. TI has taken and continues to take reasonable steps to provide representative and accurate information but may not have conducted destructive testing or chemical analysis on incoming materials and chemicals. TI and TI suppliers consider certain information to be proprietary, and thus CAS numbers and other limited information may not be available for release.

In no event shall TI's liability arising out of such information exceed the total purchase price of the TI part(s) at issue in this document sold by TI to Customer on an annual basis.

OTHER QUALIFIED VERSIONS OF CD74HCT4051-Q1 :

- Catalog: [CD74HCT4051](#)
- Military: [CD54HCT4051](#)

NOTE: Qualified Version Definitions:

- Catalog - TI's standard catalog product
- Military - QML certified for Military and Defense Applications

D (R-PDSO-G16)

PLASTIC SMALL-OUTLINE PACKAGE

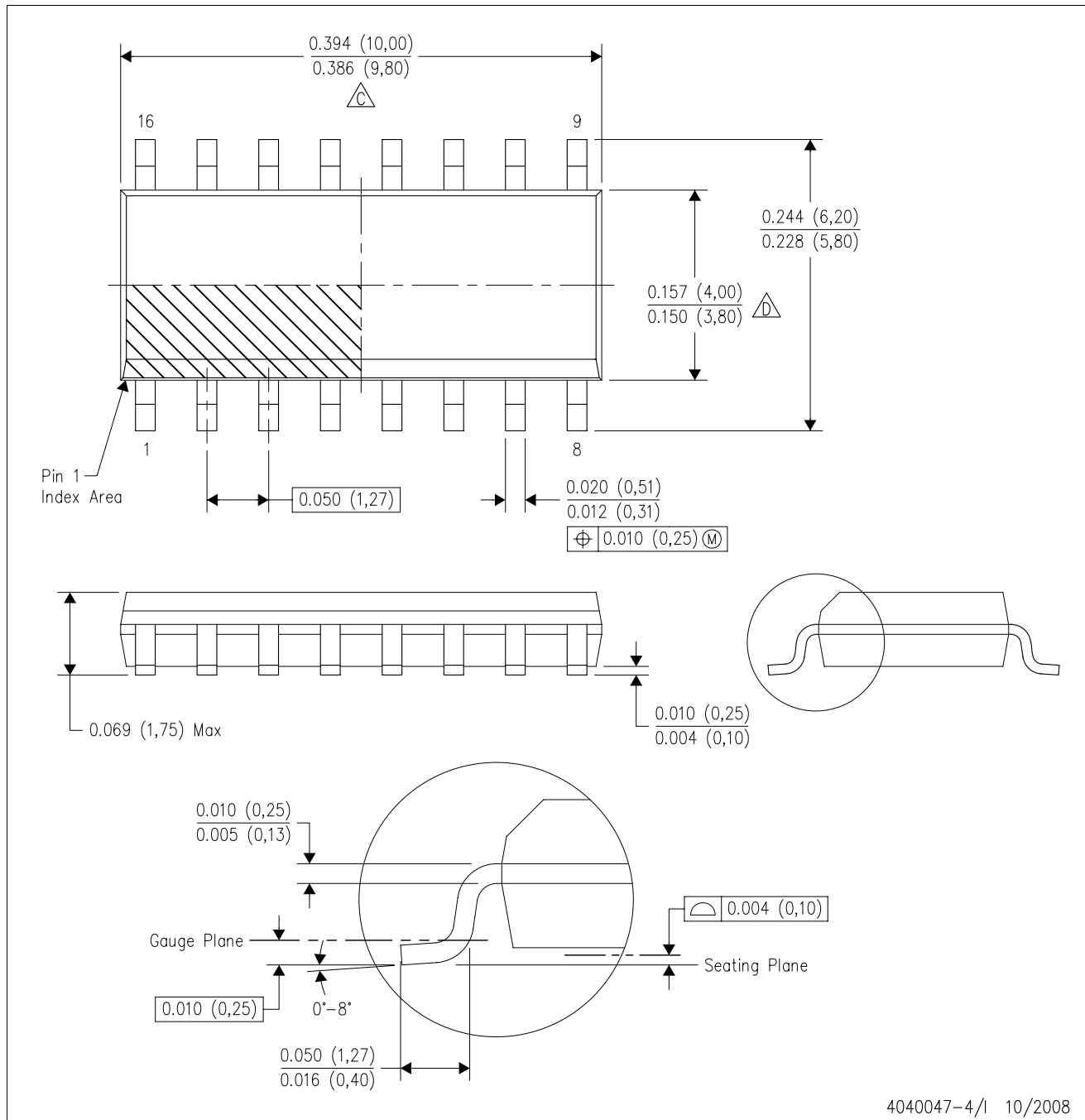

- NOTES:
- A. All linear dimensions are in inches (millimeters).
 - B. This drawing is subject to change without notice.
 - C. Body length does not include mold flash, protrusions, or gate burrs. Mold flash, protrusions, or gate burrs shall not exceed .006 (0,15) per end.
 - D. Body width does not include interlead flash. Interlead flash shall not exceed .017 (0,43) per side.
 - E. Reference JEDEC MS-012 variation AC.

D(R-PDSO-G16)

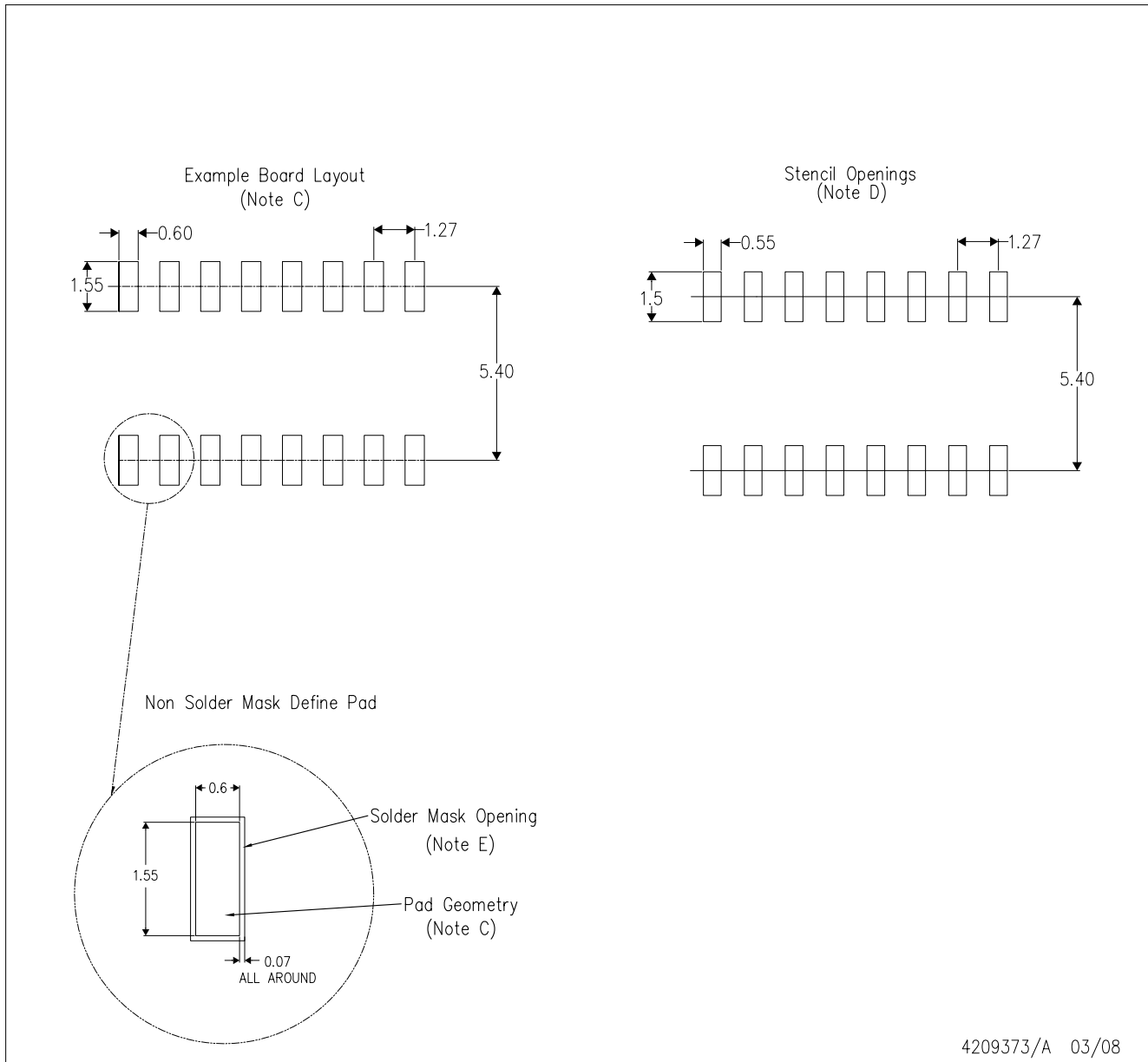

4209373/A 03/08

- NOTES:
- A. All linear dimensions are in millimeters.
 - B. This drawing is subject to change without notice.
 - C. Refer to IPC7351 for alternate board design.
 - D. Laser cutting apertures with trapezoidal walls and also rounding corners will offer better paste release. Customers should contact their board assembly site for stencil design recommendations. Refer to IPC-7525
 - E. Customers should contact their board fabrication site for solder mask tolerances between and around signal pads.

IMPORTANT NOTICE

Texas Instruments Incorporated and its subsidiaries (TI) reserve the right to make corrections, modifications, enhancements, improvements, and other changes to its products and services at any time and to discontinue any product or service without notice. Customers should obtain the latest relevant information before placing orders and should verify that such information is current and complete. All products are sold subject to TI's terms and conditions of sale supplied at the time of order acknowledgment.

TI warrants performance of its hardware products to the specifications applicable at the time of sale in accordance with TI's standard warranty. Testing and other quality control techniques are used to the extent TI deems necessary to support this warranty. Except where mandated by government requirements, testing of all parameters of each product is not necessarily performed.

TI assumes no liability for applications assistance or customer product design. Customers are responsible for their products and applications using TI components. To minimize the risks associated with customer products and applications, customers should provide adequate design and operating safeguards.

TI does not warrant or represent that any license, either express or implied, is granted under any TI patent right, copyright, mask work right, or other TI intellectual property right relating to any combination, machine, or process in which TI products or services are used. Information published by TI regarding third-party products or services does not constitute a license from TI to use such products or services or a warranty or endorsement thereof. Use of such information may require a license from a third party under the patents or other intellectual property of the third party, or a license from TI under the patents or other intellectual property of TI.

Reproduction of TI information in TI data books or data sheets is permissible only if reproduction is without alteration and is accompanied by all associated warranties, conditions, limitations, and notices. Reproduction of this information with alteration is an unfair and deceptive business practice. TI is not responsible or liable for such altered documentation. Information of third parties may be subject to additional restrictions.

Resale of TI products or services with statements different from or beyond the parameters stated by TI for that product or service voids all express and any implied warranties for the associated TI product or service and is an unfair and deceptive business practice. TI is not responsible or liable for any such statements.

TI products are not authorized for use in safety-critical applications (such as life support) where a failure of the TI product would reasonably be expected to cause severe personal injury or death, unless officers of the parties have executed an agreement specifically governing such use. Buyers represent that they have all necessary expertise in the safety and regulatory ramifications of their applications, and acknowledge and agree that they are solely responsible for all legal, regulatory and safety-related requirements concerning their products and any use of TI products in such safety-critical applications, notwithstanding any applications-related information or support that may be provided by TI. Further, Buyers must fully indemnify TI and its representatives against any damages arising out of the use of TI products in such safety-critical applications.

TI products are neither designed nor intended for use in military/aerospace applications or environments unless the TI products are specifically designated by TI as military-grade or "enhanced plastic." Only products designated by TI as military-grade meet military specifications. Buyers acknowledge and agree that any such use of TI products which TI has not designated as military-grade is solely at the Buyer's risk, and that they are solely responsible for compliance with all legal and regulatory requirements in connection with such use.

TI products are neither designed nor intended for use in automotive applications or environments unless the specific TI products are designated by TI as compliant with ISO/TS 16949 requirements. Buyers acknowledge and agree that, if they use any non-designated products in automotive applications, TI will not be responsible for any failure to meet such requirements.

Following are URLs where you can obtain information on other Texas Instruments products and application solutions:

Products

Amplifiers	amplifier.ti.com
Data Converters	dataconverter.ti.com
DSP	dsp.ti.com
Clocks and Timers	www.ti.com/clocks
Interface	interface.ti.com
Logic	logic.ti.com
Power Mgmt	power.ti.com
Microcontrollers	microcontroller.ti.com
RFID	www.ti-rfid.com
RF/IF and ZigBee® Solutions	www.ti.com/lprf

Applications

Audio	www.ti.com/audio
Automotive	www.ti.com/automotive
Broadband	www.ti.com/broadband
Digital Control	www.ti.com/digitalcontrol
Medical	www.ti.com/medical
Military	www.ti.com/military
Optical Networking	www.ti.com/opticalnetwork
Security	www.ti.com/security
Telephony	www.ti.com/telephony
Video & Imaging	www.ti.com/video
Wireless	www.ti.com/wireless

Mailing Address: Texas Instruments, Post Office Box 655303, Dallas, Texas 75265
Copyright © 2008, Texas Instruments Incorporated